

# CHOPPER BUILDERS HANDBOOK

© 2001, 02, 03, 04, 05, 06 G.W. WEISHAUP, ALL RIGHTS RESERVED.

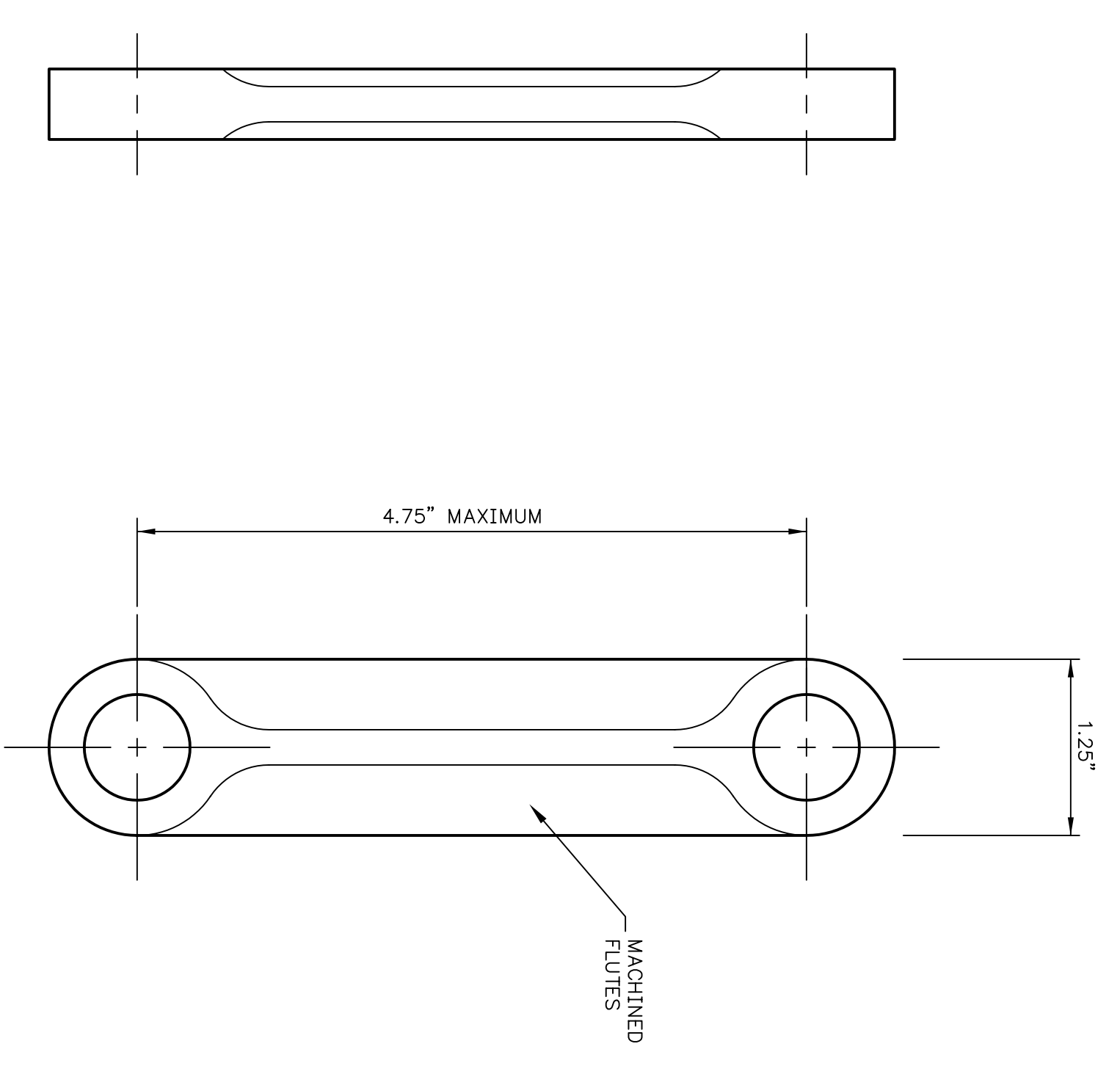

TOP VIEW

SIDE VIEW

### MACHINING OPTIONS

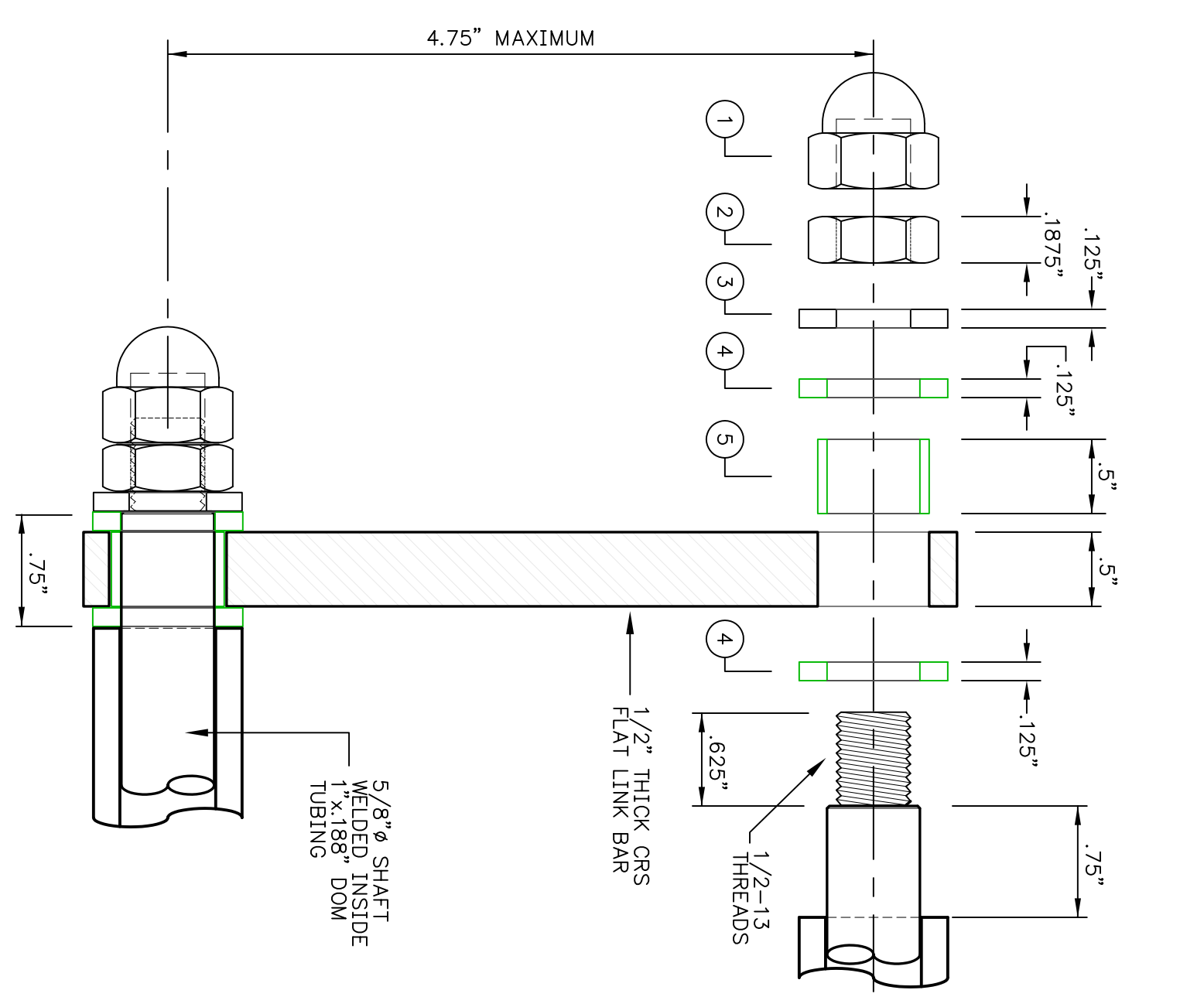

SCHEMATIC SECTIONAL VIEW

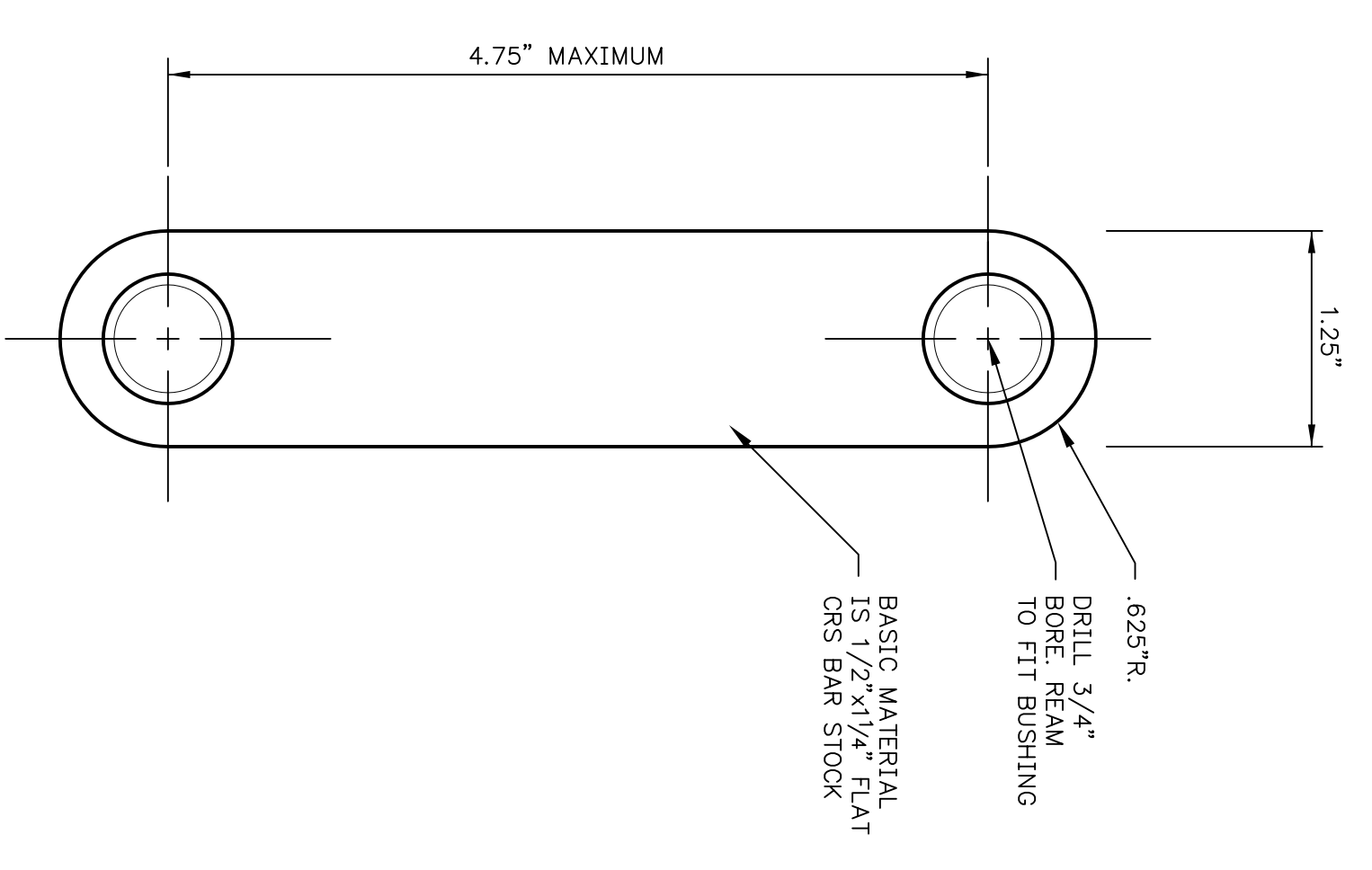

SIDE VIEW

### TYPICAL FLAT BAR LINKS

4 REQUIRED

PKT ITEM	DIMENSIONS	SOURCE
1	1/2-13 CAP NUT, NICKLE PLATED.	MAKSTER-CARR 90532A275
2	1/2-13 JAM NUT, NICKLE PLATED.	MAKSTER-CARR 9485A125
3	1/2\"/>	

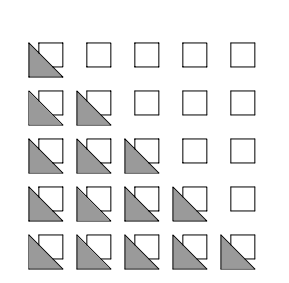

GARY W. WEISHAUP

PERFORMANCE ENGINEERING  
CHASSIS FABRICATION  
FLOWBENCH TESTING  
MACHINE WORK  
RESTORATIONS

1480 BIRCH PARK BLVD  
NAPA, CALIFORNIA 94459  
Ph: 707-255-3427  
Fax: 707-255-3427  
email: gw@22spoonline.net

Revision	Date
• INITIAL LAYOUT	5-18-04
• AS-BUILT REV.	5-28-04
• AS-BUILT REV.	2-12-00
• AS-BUILT REV.	7-13-02
• BUILDER REV.	9-3-03
• PUBLICATION	8-2-04
• PUBLICATION	1-25-08
• PUBLICATION	11-21-03
• PUBLICATION	12-18-05

Project Title  
**GIRDER FORKS  
DESIGN GF38-1**

**BASIC  
DIMENSIONS**

Drawn By	GW
Traced	12-14-05
Checked By	HC
Date	12-16-05
Scale	1" = 1"
Proj. Alt.	1" = 1"
Project No.	-

Sheet Description  
**FLAT BAR  
LINKS**

Sheet No.  
**GF1.6**